



## Glossary - Nomenclature

### Accessory

A supplementary building product, such as a door, window, skylight, ventilator, louver, etc.

### Anchor Bolt Plan

A plan view of a building(s) foundations showing all dimensions and sections required to properly locate the anchor bolts, including the projections of the bolts above the concrete surface, required recess, etc. Column reactions (magnitude and direction), and base plate dimensions are also included.

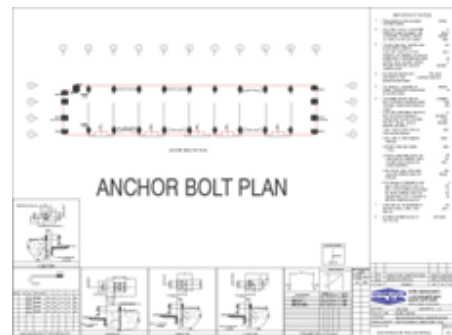

### Anchor Bolts

Bolts used to anchor structural members to a concrete floor, foundation or other support. Usually refers to the bolts at the bottom of all columns and door jambs.

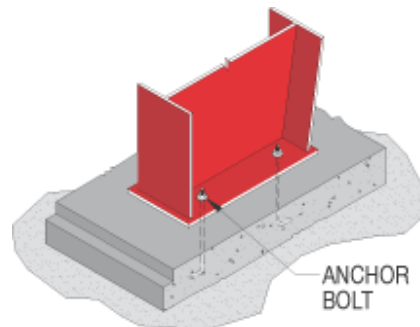

### Angle

A hot rolled member with two legs forming a 90o angle.



## Approval Drawings

Drawings sent to the customer to verify design and dimensions and to verify the sales contract description of materials and services the manufacturer has agreed to furnish.

## Assembly

Two or more components bolted together.

## Astragal

A bent plate attached to one leaf of double sliding or hinged doors to prevent dust and light ingress.

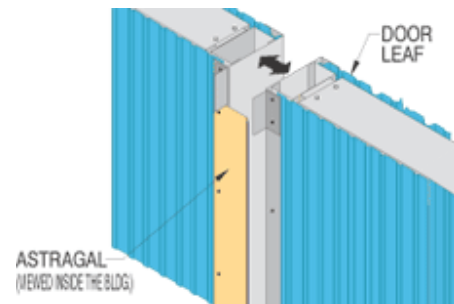

## Auxiliary Loads

All specified dynamic live loads, other than the basic design loads, which the building must safely withstand. Examples are loads imposed by crane systems, material handling systems and impact loads.

## Back-up Plates

Additional plates used in connections to provide sufficient bolt grip, allow for erection tolerances, or increase strength.



## Base Angle

A continuous angle fixed to the floor slab or to the grade beam to enable the attachment of wall panels.

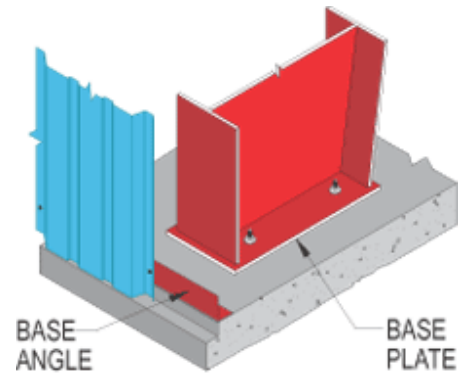

## Base Plate

The endplate of a column which rests on the supporting substructure surface.

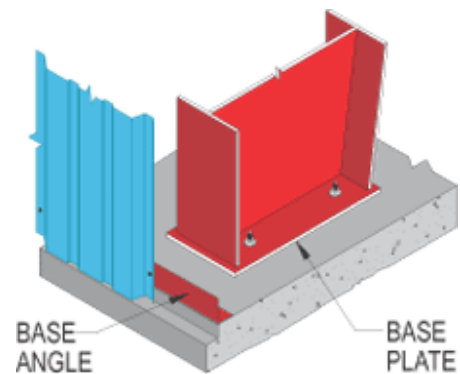

## Bay

The space between the center lines of frames or primary supporting members in the longitudinal direction of the building. Also called Bay Spacing or Bay Length.

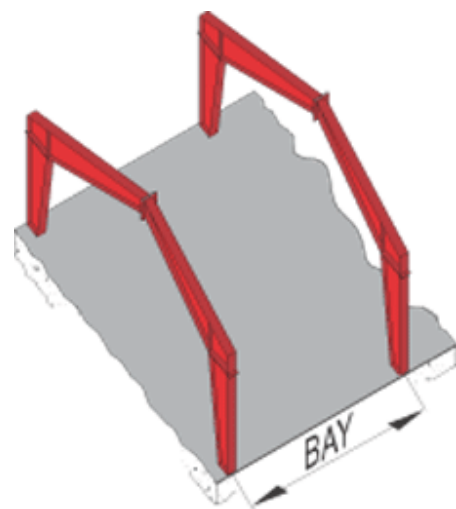



### **Bead Mastic**

A sealant furnished in a continuous roll, normally used for sealing end laps of roof panels. See also Endlap Mastic.

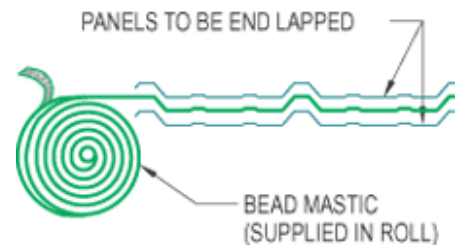

### **Beam**

A horizontal structural member designed primarily to resist moments.

### **Bent Plate**

A plate bent to form an angle.

### **Bill of Materials**

A list of items or components used for fabrication, shipping, receiving, and accounting purposes.

### **Bird Screen**

Wire mesh used to prevent birds from entering the building through ventilators, louvers and roof monitors.

### **Blind Rivet**

A small headed pin with an expandable shank for joining light gauge metal. Typically used to attach flashing, gutters, etc. Also referred to as a Pop Rivet.





## Brace Grip

Galvanized steel strands formed into a helical hair pin shape that is wrapped tightly on the strand at the end of the cable brace.

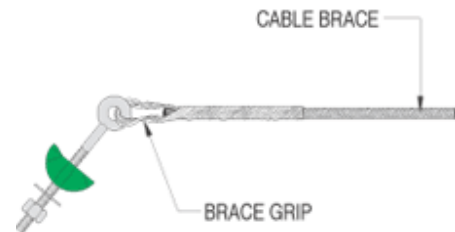

## Brace Rods/Cables

Rods or cables placed diagonally in the roof and walls for the purpose of transferring wind loads to the foundations and longitudinally stabilizing the building.

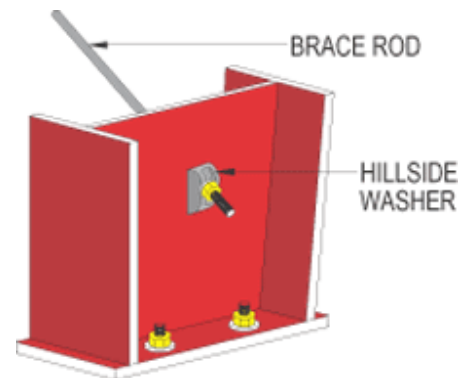

## Braced Bay

The bay where bracing is provided.

## Bracket

A structural support projecting from a column or rafter to which another structural member is fastened. Example: Brackets supporting crane runway beams.

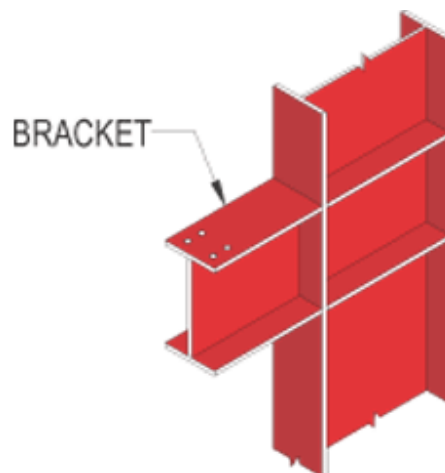



## Bridge Crane

Overhead traveling crane supported by rails which are in turn supported by crane runway beams.

## Builder

A general contractor or sub-contractor responsible for providing and erecting pre-engineered buildings.

## Building Codes

Regulations developed by recognized agencies establishing minimum building requirements for licensing, safety and functionality purposes such as setbacks, fire regulations, spacing and clearances. Building codes usually address acceptable design codes. An example of a building code is the Uniform Building Code (UBC).

## Building Width

The lateral width of the building measured from out to out of sidewall steel lines.

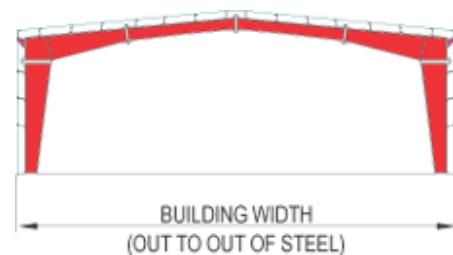

## Built-up Section

A structural member, usually an "I" shape, made from individual flat plates welded together.





### Butt Plate

The end plate of a structural member which usually rests against a similar endplate of another member to form a moment resisting connection. Also called Splice Plate, End Plate, or Cap Plate.

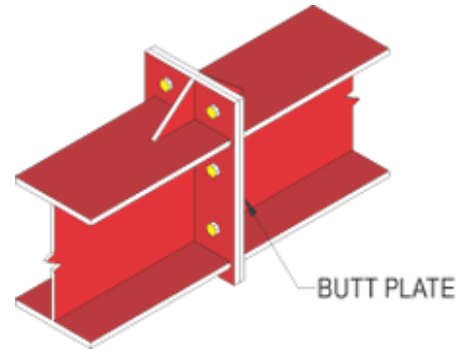

### By-pass Girt

The girt which passes continuously along the outside flanges of the columns.

### By-pass Mounted

A girt system where the girts are mounted outside the columns and are attached directly to the outside column flange.

### C Section

A member formed into a "C" shaped profile by cold roll-forming from coils.

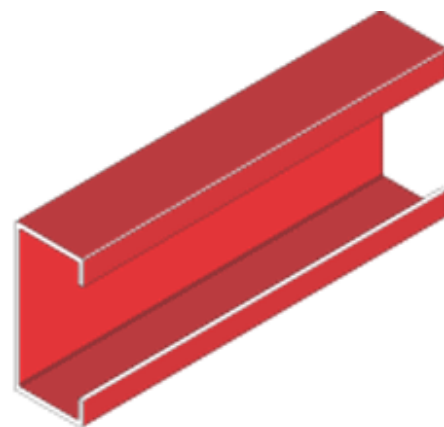

"C" SECTION (SINGLE)  
[COLD FORMED CHANNEL]



## Cable Catch Assembly

The operating handle used to open and close the ridge ventilator.

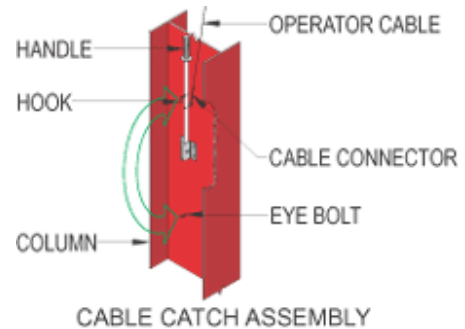

## Cables

Used for cable bracing. Can also be used to operate ridge vent dampers and for temporary bracing. See Brace Cables.

## Canopy

An overhanging or projecting roof structure, below the eave level, supported at one end only.

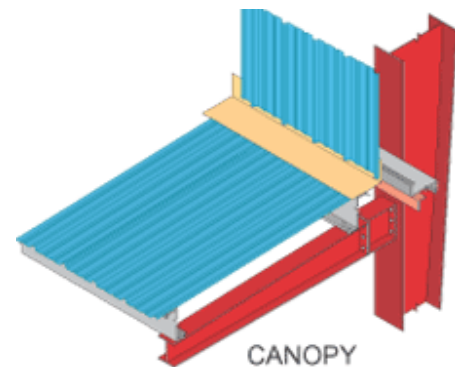

## Cantilever

A projecting beam that is supported and restrained at one end only.

## Cap Plate

A plate located at the top of a column or end of a beam. Also referred to as End Plate.





### Capillary Action

The action of water rising to a higher level.

### Catwalk

A narrow walkway used to provide access to mechanical equipment normally supported on roof platforms.

### Caulking

A sealant used in making watertight joints.

### Channel (Hot Rolled)

A member formed, while in a semi-molten state at the steel mill, into a "C" shaped profile having standard dimensions and properties specified by a relevant standard specification.

### Checkered Plate

Flat hot rolled plate with raised checkered design to prevent slipping; used for industrial equipment platforms, catwalks, stair treads, etc.

### Clear Height

The vertical dimension from the finished floor level to the lowest underside point of the rafter.

### Clear Span

A building without internal columns.

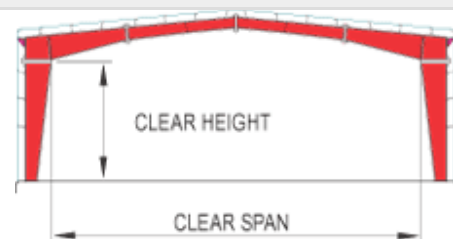



## Clip

A plate or angle used to fasten two or more members together.

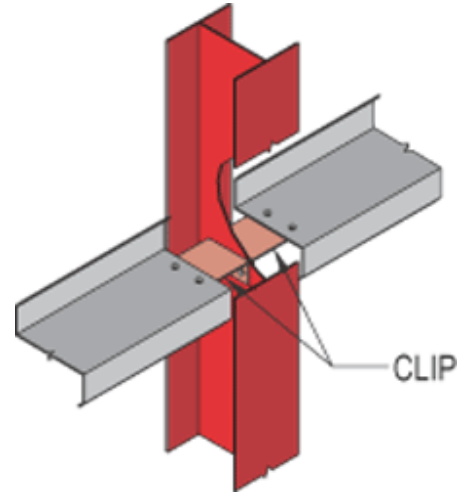

## Closer

Mechanical device, usually attached to a hinged door, which automatically closes the door.

## Closure Strip

Purpose-made foam fillers to fit inside and outside profiles of roof and wall panels providing a weather-tight seal. Also known as Foam Closure.

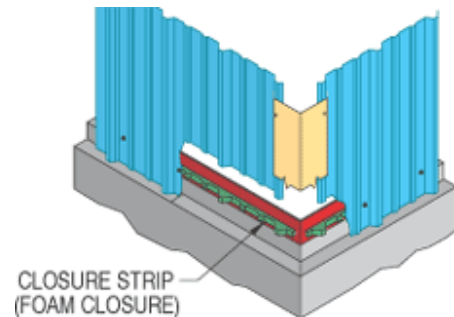

## Coil

A roll of steel sheet or wire

## Cold-Formed Member

A light gauge structural member produced from coiled steel stock running through a series of rolls at normal room temperatures.



## Collateral Load

The static load other than the basic design loads such as sprinklers, mechanical and electrical systems, ceilings, etc.

## Column

A vertical structural member used in a building to transfer loads from the main roof beams, trusses or rafters to the foundation.

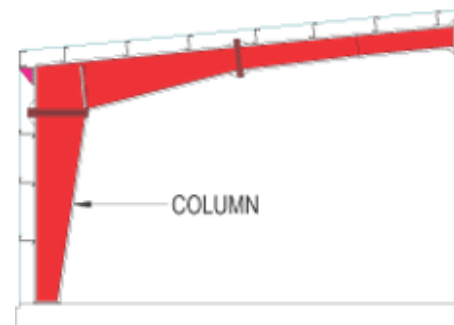

## Component

An independent part of an assembly.

## Concrete Notch

A rebate or notch formed along the edge of the concrete floor slab or grade beam, allowing wall panels to end below the floor level thus preventing ingress of dust or water.

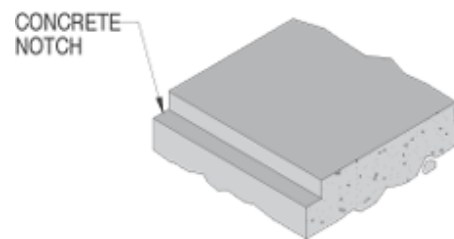



## Continuous Beam

A beam which has more than two points of support.

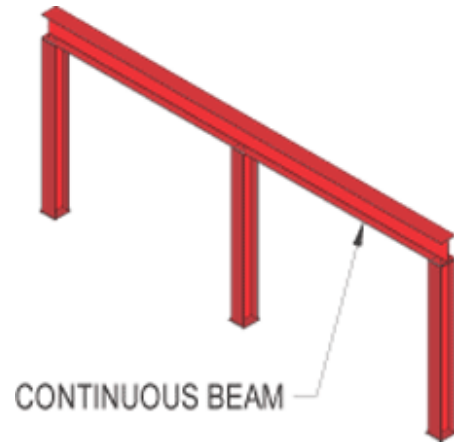

## Continuous Ridge Vent

Two or more ridge ventilators mounted on the building ridge that allow air circulation. See also Ridge Ventilator.

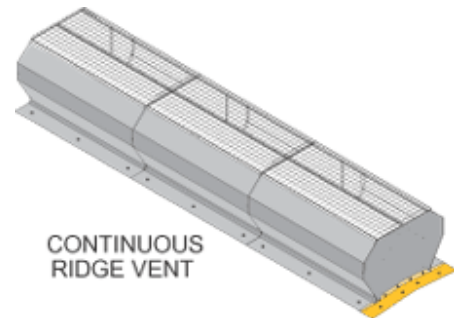

## Corner Column

A column at any corner of a building. Corner columns may be primary rigid frame columns or post-and-beam columns.

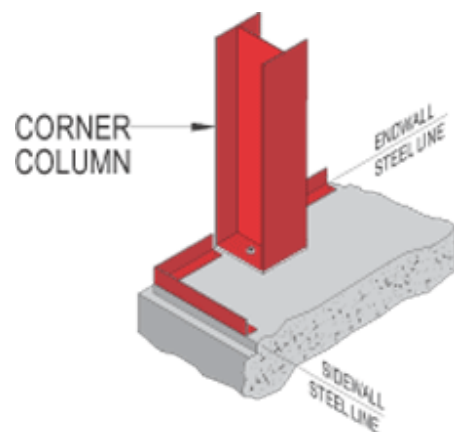

## Counter Flashing

Trim used to connect the sidewall sheeting of a main building to the roof sheeting of a lower building.



## Crane

A machine designed to lift and/or move material by means of a hoist.

## Crane Beam

A beam that supports an overhead traveling bridge crane. On underhung bridge cranes, it also acts as a crane rail. Also known as a Crane Runway Beam.

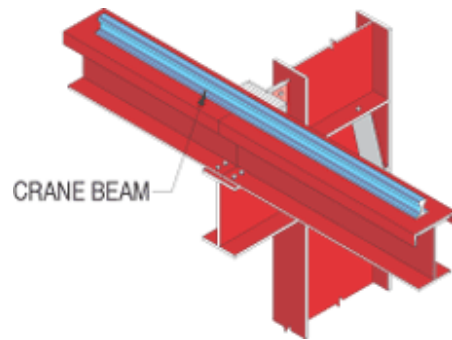

## Crane Bracket

Structural support welded to the primary building frame to permit attachment of a crane runway beam. See also Bracket.

## Crane Bridge

One or two girders or box sections supported on end carriages. See also Bridge Crane.

## Crane Capacity

The maximum weight a crane can safely lift. Crane capacity depends on the standard design of the crane components and their supports.

## Crane Rail

Rail welded or bolted to a crane beam forming the track on which the bridge crane wheels travel.



## Crane Stopper

A small vertical member welded to the top of the crane beam to stop the crane bridge at the end of the crane run area.

## Cross Section

A view formed by a plane cutting through an object usually at right angles to its axes.

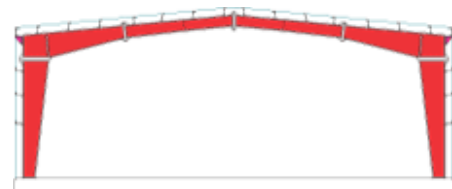

CROSS SECTION

## Curb

Raised flashing around roof openings to form waterproof openings. See also Roof Curb.

## Curved Eave

Curved panels provided at the eave.

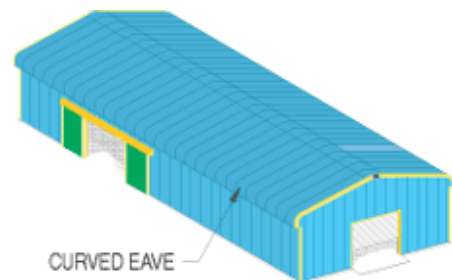

## Damper

Baffle plate in a ridge ventilator that can be opened or closed using the cable catch assembly.



## Dead Load

The self weight of the pre-engineered building structure including all its components such as frames, floors, secondary members, sheeting, bolts, etc.

## Design Codes

Regulations developed by recognized agencies establishing design loads, procedures, and construction details for structures. Examples are: MBMA, AISC, AISI, AWS, etc.

## Diagonal Bracing

Rods or cables placed diagonally in the roof and walls for the purpose of transferring wind loads to the foundations and longitudinally stabilizing the building.

## Door Guide

An angle, channel, or proprietary product used to restrain a door leaf or curtain during its opening and closing.

## Door Stopper

A clip bolted to the vertical door member to prevent opening beyond the door limit.

## Double Channel

Double or back-to-back "C" sections stitch-bolted together.

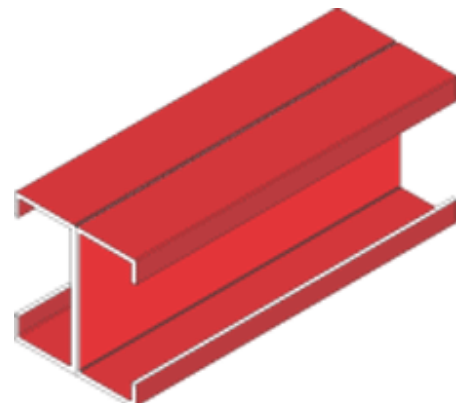

DOUBLE CHANNEL  
(DOUBLE-C SECTION)



### Double Faced Tape

Used as an aid to fix fiberglass insulation.

### Double Sliding Door

Sliding door with two door leaves.

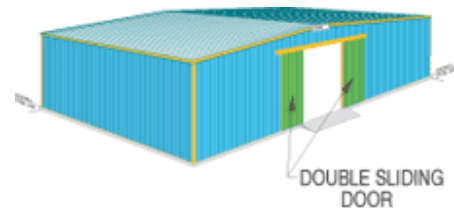

### Downspout

Cold-formed sheet metal section used to carry water from the gutter of a building to the ground or storm drainage system.

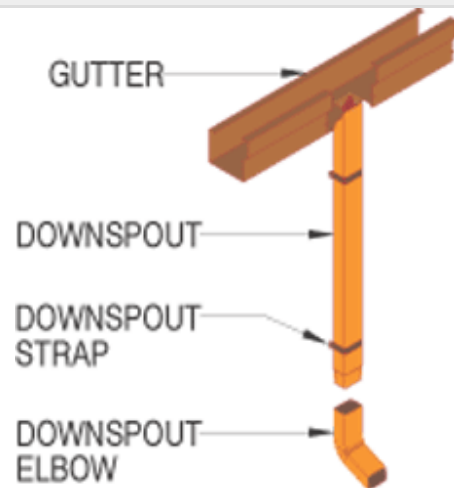

### Downspout Elbow/Shoe

Cold-formed sheet metal section, matching the downspout profile, attached to the lower end of a downspout and curved in such a way as to direct water away from a wall.

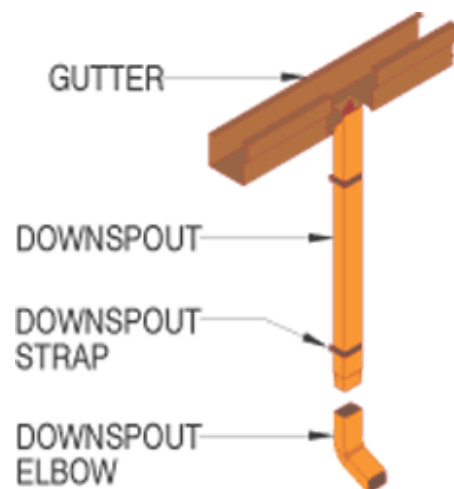





## Downspout Straps

Metal straps used to fix the downspouts to the sidewalls.

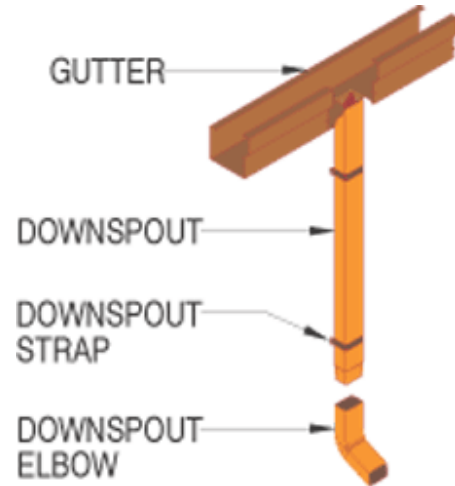

## Eave

A line along the sidewall formed by the intersection of the inside faces or planes of the roof and the sidewall panels.

## Eave Gutter

Gutter at the eave of a building.

## Eave Height

The vertical dimension from the finished floor level to the top of the eave strut.

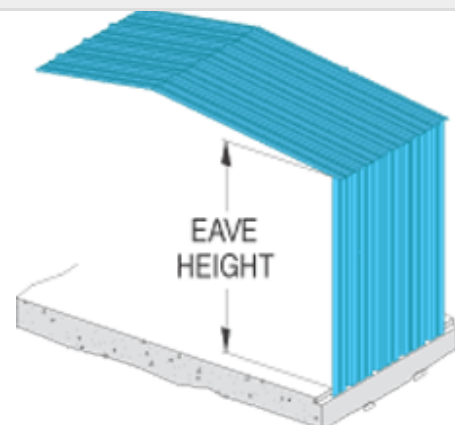



## Eave Strut

A structural member, located at the eave, used for supporting the roof panels and the wall panels.

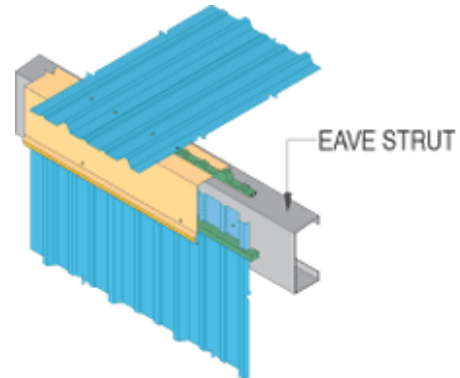

## Eave Strut Clip

A clip used to support the eave strut.

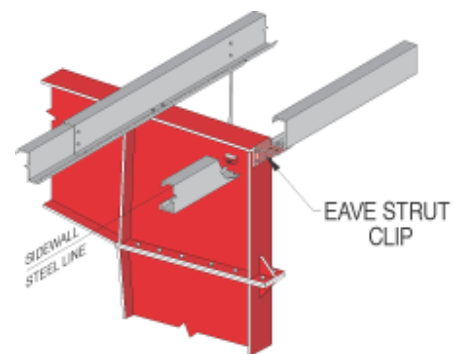

## Eave Trim/Flashing

A sheet metal closure whose function is primarily to provide weather-tightness at the eave between the eave gutter and the wall panels.

## Edge Distance

The perpendicular distance between the plate edge and the center of the bolt hole.

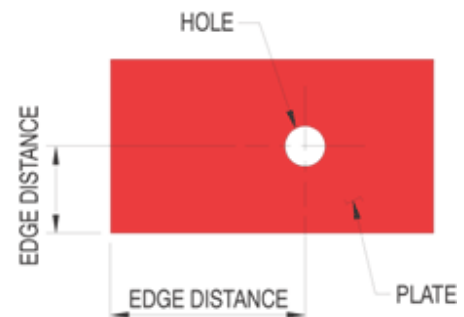



## Elevation

- (a) Distance above or below a prescribed datum or reference.
- (b) Engineering term referring to any wall view of a structure.

## End Bay

The first or last bay in the building, as opposed to interior bay. It is the spacing between the outside face of the outer flange of the endwall columns and the center line of the first interior column.

## End Framing

Framing located at the endwall of a building which supports the loads acting on a portion of the end bay.

## End Lap

A term used to describe the lap at a purlin location where the end of one panel overlaps the end of the panel below it.

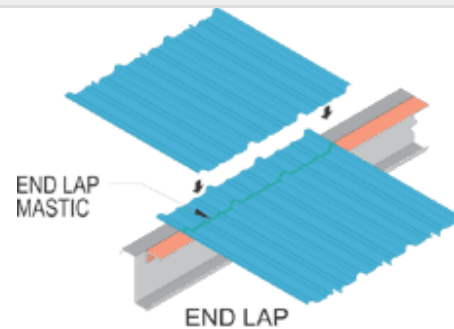

## End Lap Mastic

Sealant, in extruded bead form, used to seal end laps of roof panels for weather-tightness. Also called Bead Mastic.

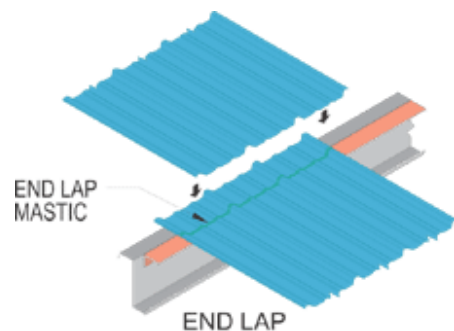



### **End Plate**

A plate welded at the end of a member.

### **Endwall**

A term used to describe the entire composition of a building end. See **Post and Beam Endwall** or **Rigid Frame Endwall**.

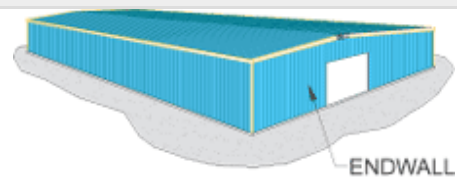

### **Endwall Post/Column**

A vertical member located at the endwall which supports the girts and endwall rafter.

### **Endwall Rafter**

Normally a cold-formed "C" section supported by end posts of post-and-beam endwalls. Endwall rafters can also be built-up or hot rolled sections if required by design loads.

### **Endwall Roof Extension**

Roof cantilevered beyond the endwall.

### **Erection**

The on site assembling of pre-fabricated components to form the complete structure.

### **Erection Drawings**

Drawings and erection instructions which identify all the individual components in sufficient detail to permit the proper assembly of all parts of the metal building system furnished by the seller.



## Expansion Joint

A weather-tight joint across the width of the building allowing for expansion and contraction.

## Exterior Mounted

A girt system where the girts are mounted outside the columns and are attached directly to the outside column flange. Also called By-pass Mounted.

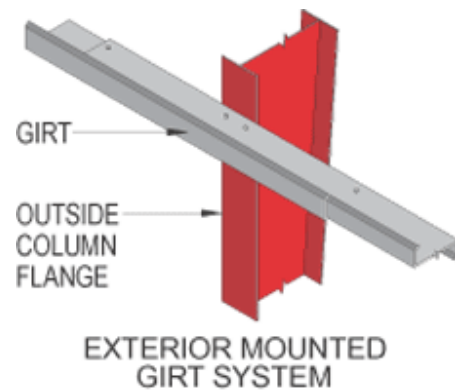

## Eye Bolt

Used in conjunction with a hillside washer for tensioning cable braces.

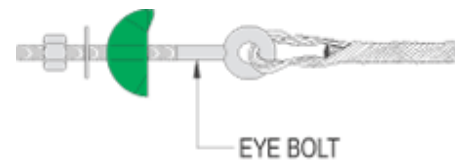

## Fabrication

The manufacturing process usually performed in a plant to convert raw material into finished metal building components. The main operations are cold-forming, cutting, punching, welding, cleaning and painting.

## Fascia

An accessory whose function is to enhance the appearance of a wall. Also used to cover the eave or gable of a building.

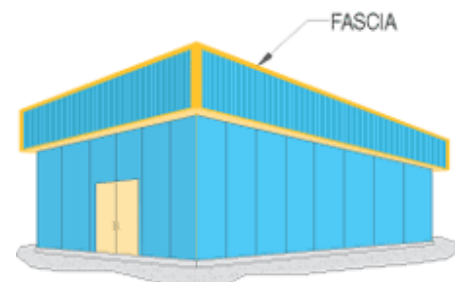



## Field Work

Modification or rectification carried out on site.

## Fin Neck Bolt

Flat dome headed bolt used in framed openings, fascias, and mezanines.

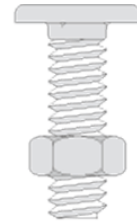

FIN NECK BOLT W/ NUT

## Finished Floor

Top of the concrete slab or the finished concrete surface.

## Fixed Base

A column base that is designed to resist rotation as well as horizontal or vertical movement.

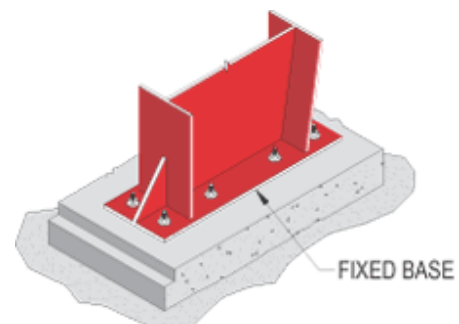

## Flange

The projecting edge of a structural member.

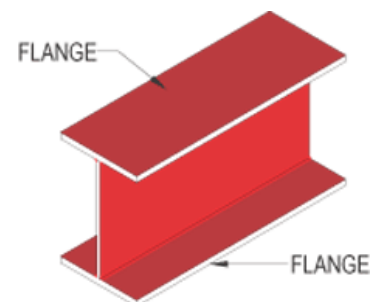



## Flange Brace

An angle member extending between girts or purlins to the inner flange of columns or rafters respectively, to provide them with lateral support and stability.

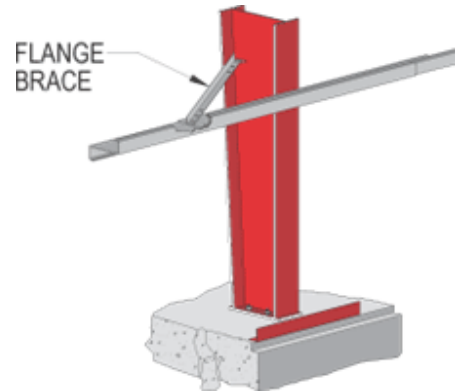

## Flashing

A sheet metal closure used to provide weather-tightness in a structure.

## Flowable Mastic

Supplied in a nozzled cartridge. Used to seal overlapping flashing, gutter joints, etc.

## Flush Mounted

A girt system where the outside flanges of the girts and columns are flush. The girts are supported by the use of girt clips bolted to the column webs.

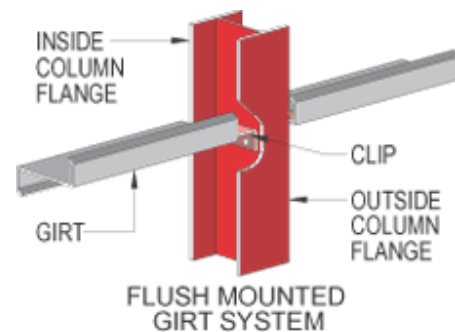

## Footing

Reinforced concrete base that provides support for a column.

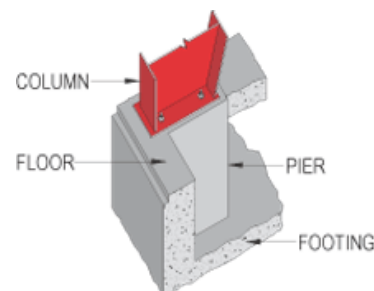



## Force

The action of one body on another body which changes or tends to change its state of rest or motion. A force may be expressed in kilonewton(s) (kN), or other similar units.

## Foundation

The substructure which supports a building or other structure. Usually constructed in concrete.

## Framed Opening

Framing (headers, sills, and jambs) and flashing which surround an opening in a building. Usually provided to accommodate field installed accessories such as sliding doors, roll-up doors, etc.



## Framing

Primary and secondary members (columns, rafters, girts, purlins, brace cables, etc.) which when connected together make up the skeleton of a structure to which the covering can be fastened.

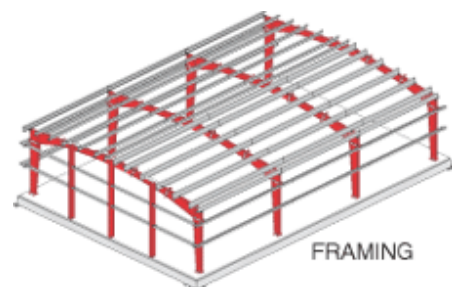

## Gable

The triangular portion of the endwall of a building directly under the sloping roof and above the eave height line.





### **Gable Angle**

An angle fastened to the purlins at rake for the attachment of endwall sheets.

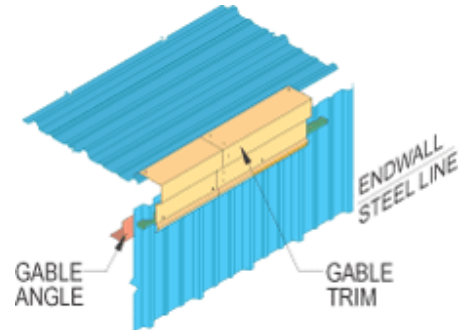

### **Gable Trim**

A flashing designed to close the opening between the roof panels and endwall panels.

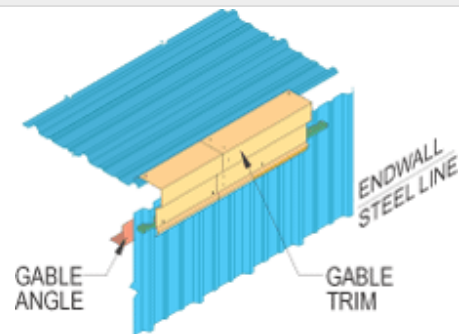

### **Gage**

The distance between holes along the transverse axis of a plate.

### **Galvanized**

Steel coated with a layer of zinc for corrosion resistance.

### **Gauge**

The distance between holes along the transverse axis of a plate.

### **Girder**

A horizontal structural member designed primarily to resist moments.



## **Girt**

Secondary horizontal member attached to the main frame columns. Girts normally support wall panels.

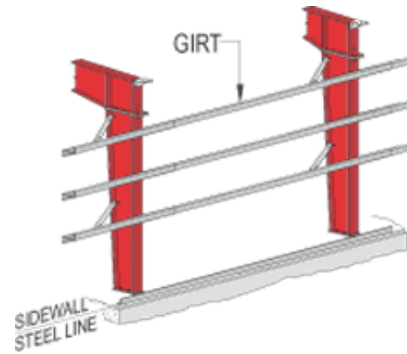

## **Girt Clip**

Angle clips used to connect girts to the endwall columns.

## **Glazing**

Installation of glass.

## **Grade**

Ground level (or elevation) surrounding a building.

## **Grating**

Welded framework of crossbars used in flooring of equipment platforms, platform walkways, catwalks and stair treads.

## **Grout**

Non-shrinking sand and cement based mixture used under base plates to obtain a uniform bearing surface.



## Gusset Plate

Steel stiffener plate used to help distribute load at a connection.

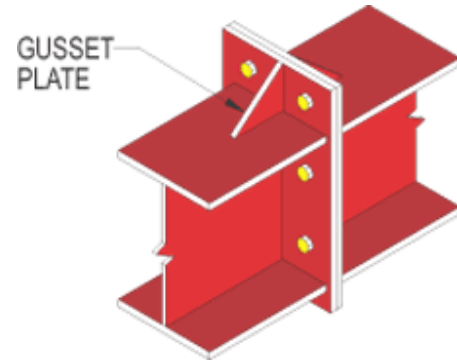

## Gutter

Pre-formed light gauge metal channel at the roof, along the sidewalls, or in valleys of multi-gabled roofs for the collection of rainwater.

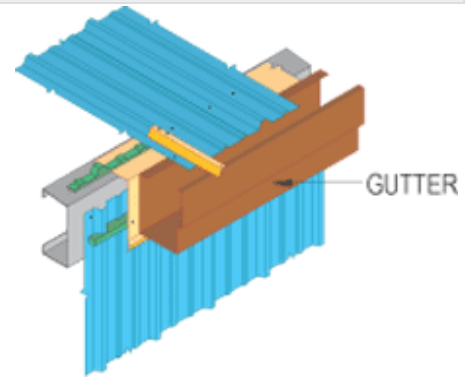

## H Section

A steel member with an "H" cross section.

## Hair Pin

Reinforcement bars used in distributing forces from the column foundation to the floor slab.

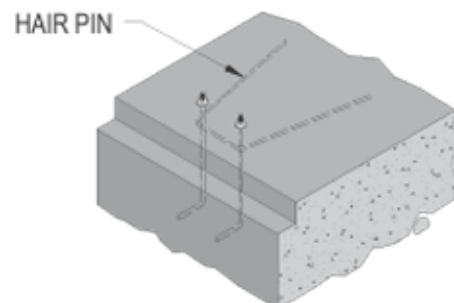



## Handrails

Horizontal and vertical pipes fixed to stair stringers, edges of mezzanine floors, openings in floors and platform walkways.

## Hangar Door

A large multi-leaf door that is used in aircraft hangars or similar buildings.



## Haunch

Intersection of the column and rafter. Also referred to as Knee.

## Header

A horizontal member over an opening in a wall.

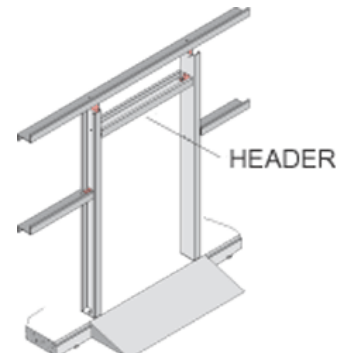

## High Strength Bolt

Any bolt made from steel having a tensile strength in excess of 690 megapascal (MPa). Some examples are: ASTM A325, A354, A449 and A490.



### **Hillside Washer**

A washer having non-parallel faces normally used on brace cables or rods. Also known as Bevel Washer.

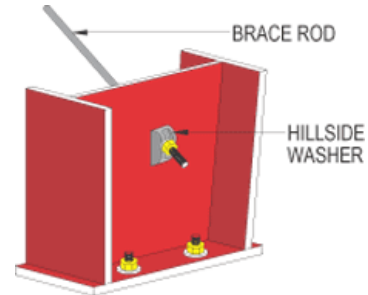

### **Hinged Base** (See Pinned Base.)

### **Pinned Base**

A column base that is designed to resist horizontal and vertical movement, but not rotation.

### **Hoist**

A lifting device that is mechanically, electrically or manually operated.

### **Horizontal Knee Splice**

Horizontal connection of the column to the rafter.

### **Hot Rolled Shapes**

Steel sections (angles, channels, I-sections, etc.) which are formed, while in a semi-molten state at the steel mill, into a shape having standard dimensions and properties specified by relevant standard specifications.

### **Impact Load**

A dynamic load resulting from the motion of machinery, craneways, elevators and other similar moving forces.



## Insulation

Any material used in building construction for the reduction of heat transfer.

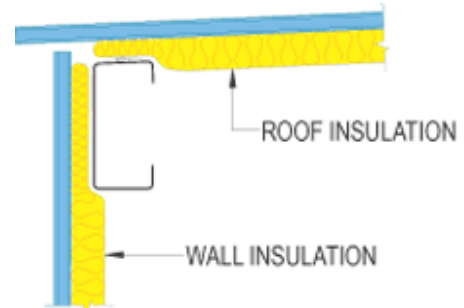

## Interior Bay

The distance between the center lines of two adjacent interior rigid frames.

## Intermediate Rafter Splice

Connection of two pieces of the rafter.

## Jack Beam

A primary horizontal member used to support another beam, truss or rafter.

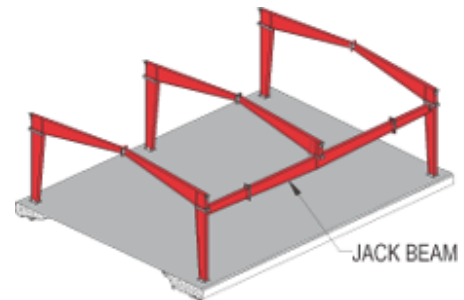

## Jamb

Vertical member at the side of a wall opening.



## Jib Crane

A cantilever boom or horizontal beam with a hoist and trolley.

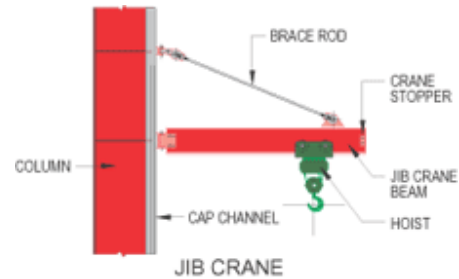

## Joist

A horizontal member for supporting the decking of floors or roofs.

## Knee

Intersection of the column and rafter.  
Also referred to as Haunch.

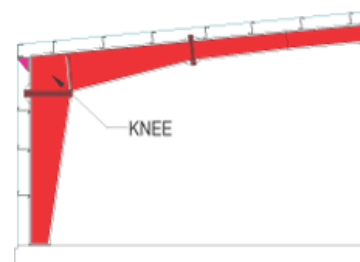

## Lean-To

A structure dependent upon another structure for partial support and having only one slope or pitch.

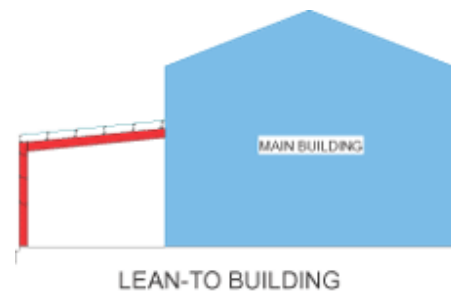

## Liner Panel

Interior wall or roof sheeting attached to the inside flanges of the girts or purlins.



### **Lintel**

A beam (either concrete or steel) in masonry walls placed above doors, windows or openings to support masonry above.

### **Live load**

Any variable load that results from intended use of the structure during its life time.

### **Loads**

Anything that causes a force to be exerted on a structural member. Examples of different types of loads are:

- a. Dead Load
- b. Live Load
- c. Impact Load
- d. Seismic Load
- e. Wind Load
- f. Crane Load
- g. Auxiliary Load
- h. Collateral Load

### **Longitudinal**

The direction parallel to the ridge line.





## Louver

A wall opening provided with slanted blades, fixed or movable, to allow flow of air inside the building.

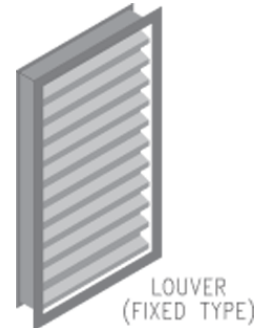

## Machine Bolts

Mild steel bolts conforming to ASTM A307 standard specifications.

## Masonry

Construction materials such as bricks, concrete blocks and stone.

## Mastic

See **Caulking**.

## Mezzanine

An intermediate floor within a building above the ground floor that occupies all or part of the building floor area and consists of columns, beams, joists, deck panels and edge trims to receive reinforced concrete.

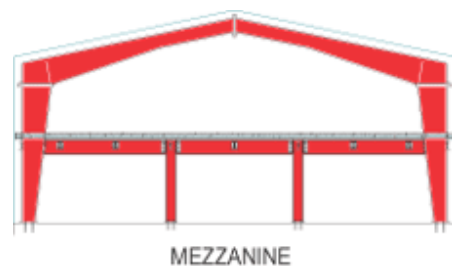

## Moment

The tendency of a force to cause rotation about a point or axis.



## Moment Connection

A connection designed to transfer moment, as well as axial and shear forces, between connecting members.

## Monorail Beam

A single beam support for a material handling system. It is normally a hot rolled "I" beam.

## Mono-Slope

A building sloped in one direction.

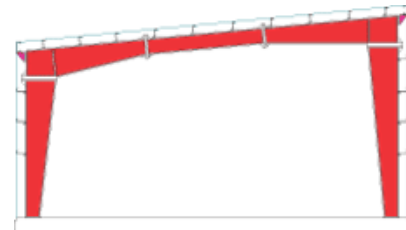

MONO-SLOPE BUILDING

## Mullion

A vertical bar or pier between panes or sections of windows and screens.

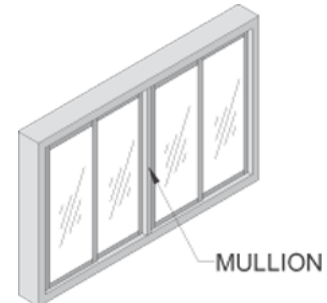

MULLION

## Multi-Gable Buildings

Buildings consisting of one or more gables across the width of the building.



MULTI-GABLE BUILDING

## Multi-Span Buildings

Buildings with interior columns.

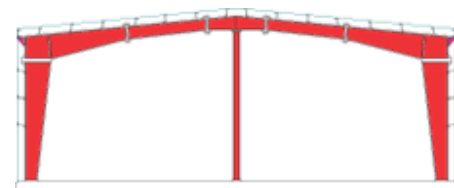

MULTI-SPAN BUILDING



### **Notch**

A rebate. See also **Concrete Notch**.

### **Panel**

A piece of roof or wall sheeting. See also **Sheeting**.

### **Parapet Wall**

That portion of the vertical wall which extends above the roof line at the intersection of the wall and roof.

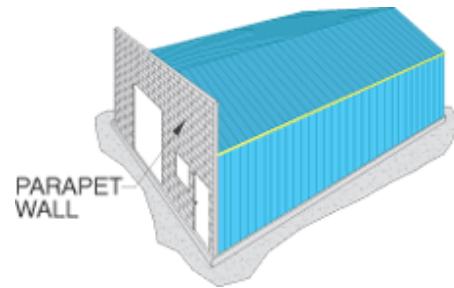

### **Part Mark**

A number physically marked on a piece or packing that identifies each component of the building for erection and shipping purposes.

### **Partition**

A non-load bearing interior dividing wall. It can sustain its own weight but does not support the ceiling or roof and is designed to withstand a maximum lateral load of 0.25 kN/m<sup>2</sup>.

### **Peak**

The uppermost point of a gable. Also called Peak Point or Ridge Point.

### **Peak Panel**

Also known as Ridge Panel. Used to link and weather-seal roof panels on opposing slopes.



## Peak Sign

A sign attached to the peak of the building at the endwall showing the name of the manufacturer of the building. Also called Ridge Sign.

## Personnel Door

An access door.

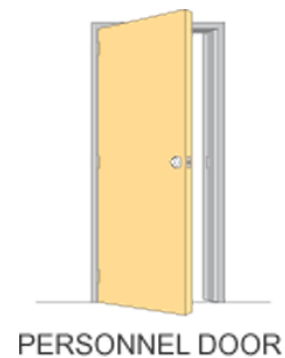

## Pier

A concrete structure designed to transfer the vertical load from the column base to the footing.

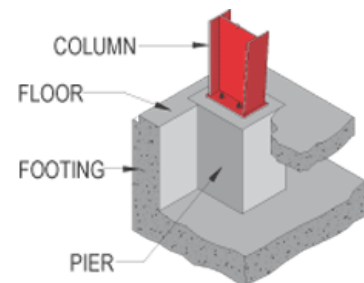

## Pilot Door

A small access door within one leaf of a sliding door. Also called Wicket Door.

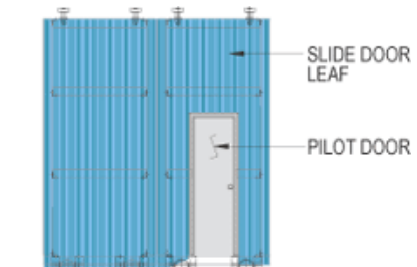

## Pin Connection

A connection designed to transfer the axial and shear forces between connecting members, but not moment forces.



## Pinned Base

A column base that is designed to resist horizontal and vertical movement, but not rotation.

## Pipe Flashing

Used in sealing roof penetrations.

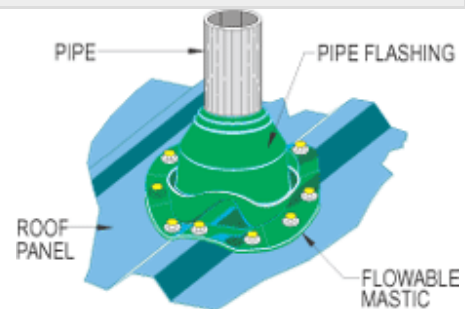

## Pitch (Hole)

Distance between center lines of holes along longitudinal axis of plate.

## Pitch (Roof)

Slope of the roof

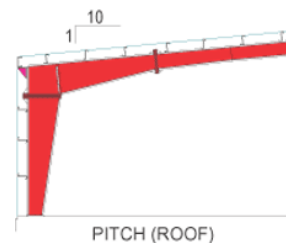

## Plan

Details of a building as viewed from the top.

## Pop Rivet

Used for joining flashing and light gauge metal trims. See also **Blind Rivet**.



## Portal Frame

Column and beam bracing used in lieu of standard diagonal cable bracing to provide clear access.

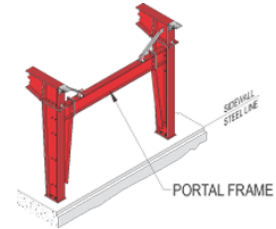

## Post-and-Beam Endwall

A system of endwall framing consisting of vertical columns (posts), with pinned ends, which support rafters (beams). These posts and beams are normally light members made from cold-formed sections.

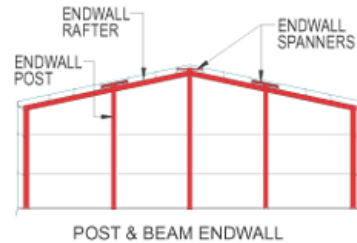

## Pre-Engineer

To design and detail components beforehand.

## Pre-Fabricate

To fabricate parts in the shop beforehand. To manufacture standard sections that can be rapidly assembled.

## Primary Framing

The main load carrying members of a structural system, generally the columns, rafters, and/or other main support members.



## Primer Paint

The initial coat of paint applied in the shop to the structural framing of a building for protection against aggressive environmental conditions during shipping and erection.

## Purlin

A horizontal secondary structural member, bolted to the rafters, which transfers the roof loads from the roof covering to the primary frames.

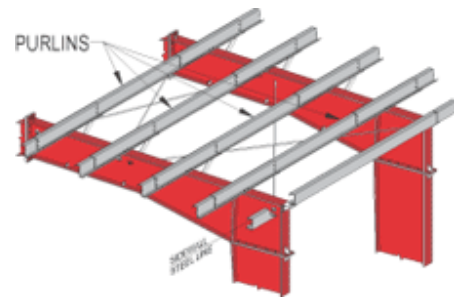

## Purlin Extension

A projecting secondary member used in roof extensions at the endwall.

## Purlin Line

The line joining the extreme outer, or exterior, edges of the purlins parallel to the frames

## Rafter

A primary beam member supported on columns.

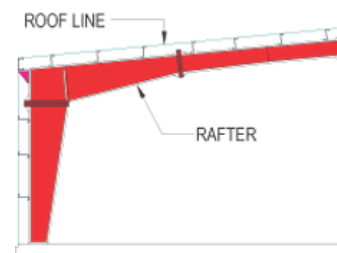

## Rake

The intersection of the plane of the roof and the plane of the gable.



## Rake Trim

The sheeting item joining the roof and wall sheeting at the rake. Also called Gable Trim.

## Reactions

The resisting forces, at the column bases of a frame, holding the frame in equilibrium under a given loading condition.

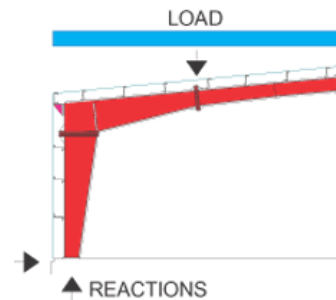

## Revision

A change that is made to the building design, component details, location of accessories, etc.

## Ridge

The peak, or highest point of a gabled building, which describes a horizontal line running the length of the building.

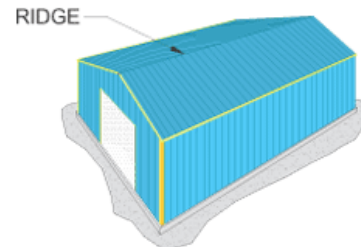

## Ridge Connection

A connection, between two rafter members, which transfers the moment from one side of the connection to the other and maintains, under application of load, the same angle between the connected members that exists prior to the loading. See also [Moment Connection](#).

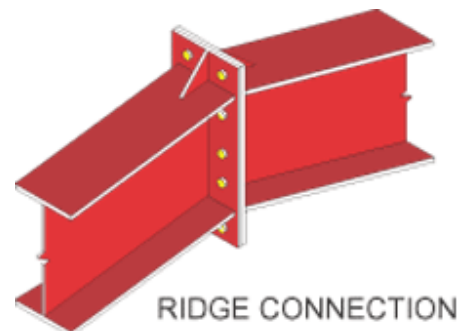





## Ridge Flashing

Continuous metal flashing used to close roofing material along the ridge of a roof. Also called Ridge Cap or Peak Panel.

## Ridge Sign

The manufacturer's sign at the peak or highest point of the gable. Also called Peak Sign.

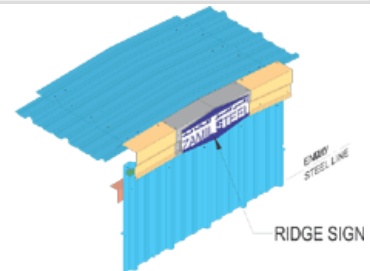

## Ridge Ventilator

The ventilator used at the ridge line.

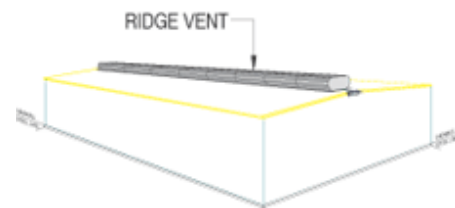

## Rigid Frame

A structural frame consisting of members joined together with rigid (or moment) connections so as to render the frame stable with respect to imposed loads, without the need for bracing in its plane.

## Rigid Frame Endwall

A system of endwall framing where the main interior frame is used at the endwall mostly for the purpose of future expansion.

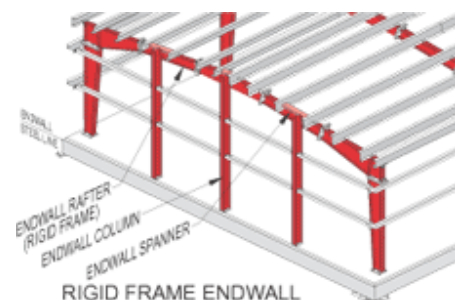



## Risers

The vertical rise of the steps of a staircase.

## Roll-Up Door

A door which opens vertically and is supported on a shaft or drum and runs along vertical tracks.

## Roof Covering

The exterior roof skin consisting of panels or sheets, their attachments, and weather sealant.

## Roof Curb

Weatherproof flashing used on roofs to support power ventilators or ducting. Roof Curbs can be fiberglass or sheet metal.

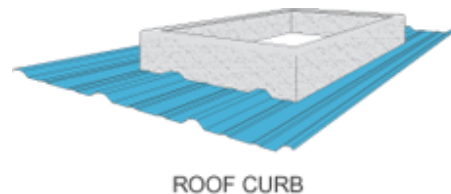

## Roof Extension

An extension of the roof beyond the endwall and/or sidewall of a building.

## Roof Monitor

Raised gable, or portion of the main building, located at the ridge, to allow lighting and ventilation.

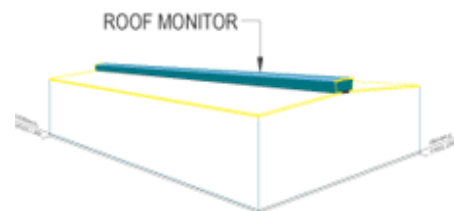

## Roof Slope

The angle that a roof surface makes with the horizontal. Usually expressed in units of vertical rise to 10 units of horizontal run.



### **Sag Rod**

A tension member used to limit the movement of a girt or purlin in the direction of its weak axis before the installation of sheeting.

### **Secondary Framing**

Members which carry loads to the primary framing. In metal buildings this term includes purlins, girts, eave struts, flange braces, etc.

### **Seismic Load**

The assumed lateral load acting in any horizontal direction on the structural system due to earthquakes.

### **Self Drilling Fasteners**

Fasteners, used for attaching panels and trims to girts and purlins, which drill their own holes and eliminate the pre-drilling operation.

### **Self Drilling Screws (SDS)**

Fasteners, used for attaching panels and trims to girts and purlins, which drill their own holes and eliminate the pre-drilling operation.

### **Self Tapping Screws (STS)**

Have the same function as SDS but need pre-drilled holes.

### **Sheeting**

Profiled metal panels.

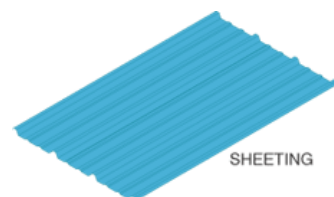



## Sheeting Angle

An angle used to support sheeting.

## Shims

Small steel plates used for levelling base plates or for packing between structural members.

## Shipping List

A list that enumerates, by part number or description, each piece of material or assembly to be shipped. Also known as Packing List.

## Shop Details

Drawing details for fabrication of parts and assemblies.

## Side Lap

A term used to describe the lap at the side or lengthwise direction of panels.

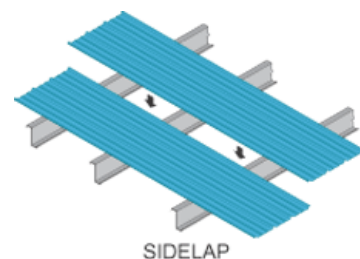

## Sidewall

A term used to describe the entire composition of a building side which is parallel to the ridge.

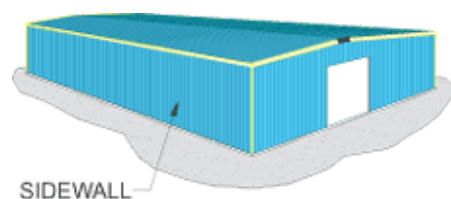



## Sill

The bottom horizontal member of a door or window opening.

## Simple Span

The term used in structural engineering to describe a support condition, for a beam, girt, purlin, etc., which offers no resistance to rotation at the supports.

## Single Slope Building

See **Mono-Slope**.

## Skylight

A translucent panel used at the roof to transmit natural light. It is usually made of fiberglass

## Slats

Flat strips used in the shutters of roll-up doors.

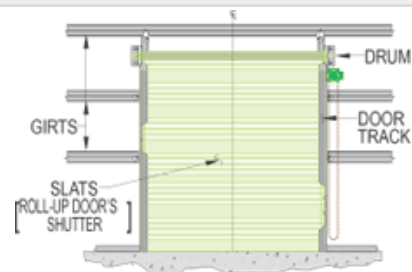

## Sleeve Nut

A long nut normally used to join two brace rods of the same diameter together. Also known as Coupling.

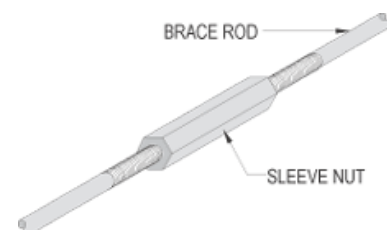



## Sliding Door

A single or double leaf door which opens horizontally by means of overhead trolleys or bottom wheels.

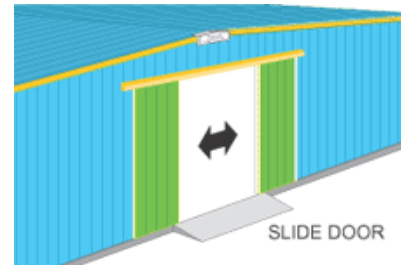

## Slot

An elongated hole.

## Soffit

The underside covering of any exterior portion of the metal building such as canopies, sidewall and endwall roof extensions.

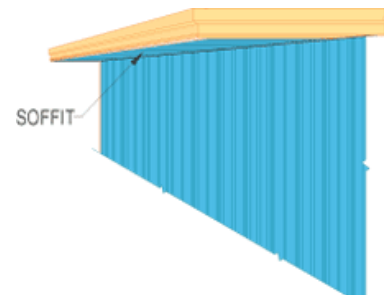

## Soil Pressure

The load, per unit area, a structure will exert, through its foundations, on the soil.

## Soldier Column

A column, in sidewalls outside the main frame lines, located in extended bays to support sidewall girts, wall canopies and Lean-To's.

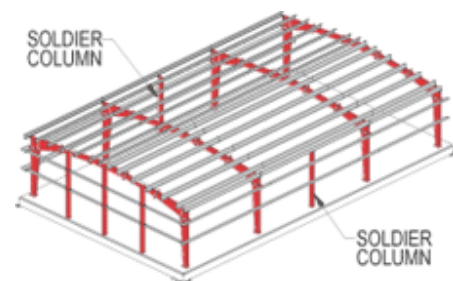



## Space Saver

Building with a single gable clear span and straight columns. Wall girts are flush mounted.

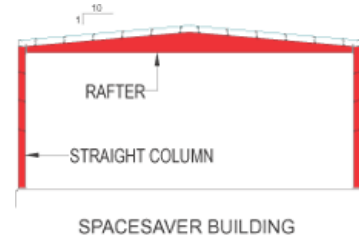

## Span

Distance between the supports of beams, girders or trusses. In a pre-engineered building distance between interior columns.

## Spanner

A component used to connect the endwall post (column) to the endwall roof purlins

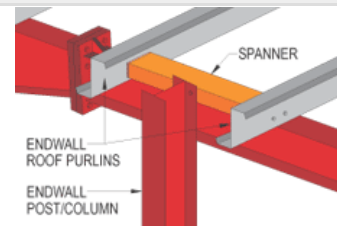

## Specification

A statement of particulars defining physical dimensions, strength and other properties, or a statement defining performance expectations of materials or devices.

## Splice

The connection between two structural members.

## Steel Line

The extreme outer limits of the structural framing system of a building to which the sheeting is attached.



### Step in Eave Height

The condition where a lower building is attached to a higher building at the endwalls, resulting in one building with different eave heights at each end. Sometimes called Roof Transition.

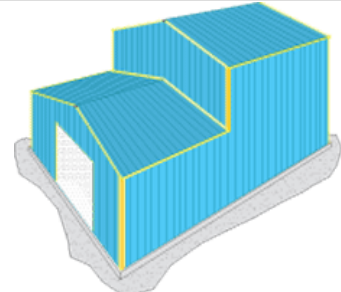

STEP IN EAVE HEIGHT

### Stiffener

Plate welded to a member to increase strength of the web or to provide continuity at connections.

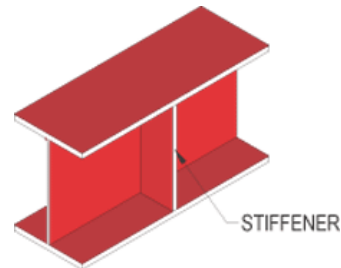

### Stiffening Lip

A short extension of material, at an angle to the flange of cold-formed structural members, which adds strength to the member.

### Stiles

The vertical side members of a door frame.

### Stitch Screws

Fasteners used to fasten side laps of panels and for attaching trims or flashing.

### Structural Steel Members

Load carrying members. May be hot rolled sections, cold-formed shapes, or built-up sections.





## Strut

A brace fitted into a framework to resist force in the direction of its length.

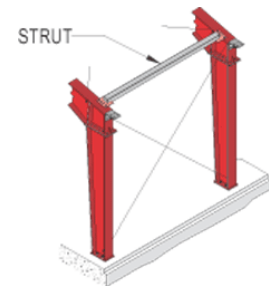

## Strut Purlin

An additional purlin, in braced bays, located close to the normal purlin at the intersection of roof brace rods or cables and the frame rafter, as required by design.

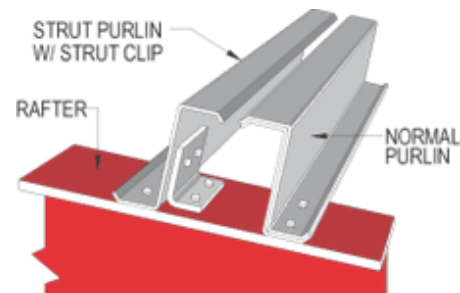

## Suction

A partial vacuum, resulting from wind loads on a building, which causes a load in the outward direction.

## Tapered Member

A built-up plate member consisting of flanges welded to a web of variable depth.

## Tempcon Panel

A panel assembly consisting of an insulated core material sandwiched between an interior and exterior skin panel. Sometimes called Sandwich Panel.

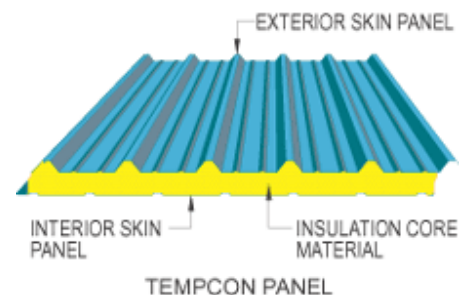



## Throat

Minimum width of the ventilator air inlet.

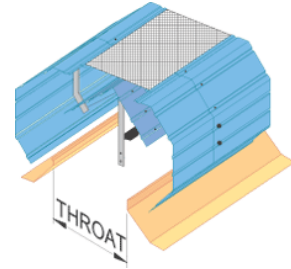

## Thrust

A horizontal component of a reaction.

## Tolerance

A fractional allowance for variations from the specified standard weight, dimensions, etc., of mechanical construction.

## Track

A metal way for wheeled components, specifically one or more lines of ways, with fastenings, ties, etc., for a craneway, monorail or sliding door.

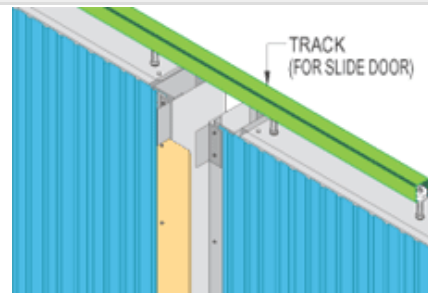

## Translucent

Allowing the passage of light, but not permitting a clear view of any object. A translucent material is semi-transparent or semi-clear.

## Transverse

From sidewall to sidewall of a building



### **Tread**

The horizontal step of a staircase.

### **Trim**

Pre-formed light gauge metal used as a cover to cut edges, sides or junctions of sheeting.

### **Truss**

A structural member, made up of several individual parts welded or bolted together, designed to carry a tension or compression force with the complete structure acting as a beam.

### **Tube Column**

A vertical structural support member made of a hollow square tube. Normally used as an interior support column in Multi-Span buildings or mezzanine floors.

TUBE COLUMN



### **Turn-of-Nut Method**

A method of tightening high strength bolts in accordance with AISC: "Specifications for Structural Joints using ASTM A325 Bolts".

### **UL Rating**

Underwriters Laboratories certification rating for reliability and quality



## Under Hung Crane

Bridge crane hanging from beams, rather than supported on beams.

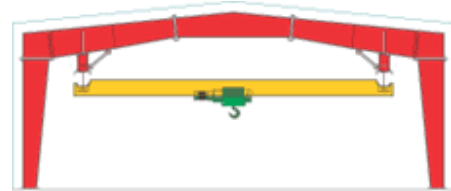

UNDERHUNG (UH) CRANE

## Uniform Load

Load that covers all or part of a beam or surface where, throughout the portion covered, the intensity of load per unit of length or area is the same.

## Uplift

Wind load on a building which causes a load in the upward direction. See also **Suction**.

## Valley Gutter

A channel used to carry off water, normally from roofs of multi-gabled buildings.

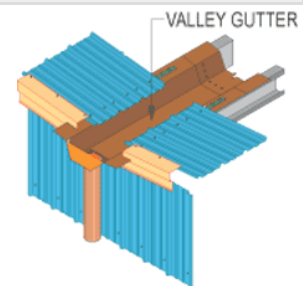

## Vapor Barrier

Material used to retard the flow of vapor or moisture into walls and roofs and thus prevent condensation within them.

## Ventilation

The process of changing the air within a building.

## Ventilator

A means of providing air changes within a building.



## Wall Covering

The exterior wall skin consisting of panels or sheets and their attachments, trims and weather sealants.

## Web

That portion of a structural member between the flanges.

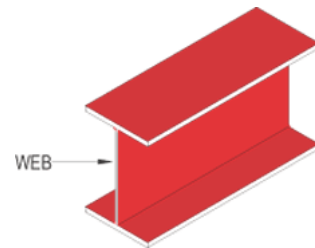

## Wheel Base

The distance between the two wheels of a crane along the crane beam.

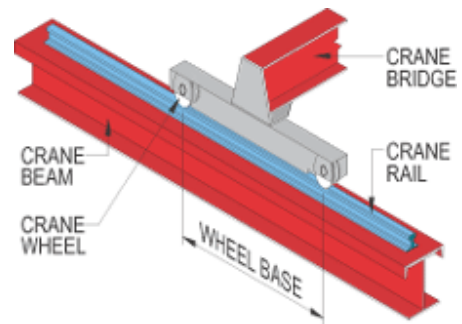

## Wheel Load

The maximum load which is transferred through the wheels of a crane to a crane beam.

## Width Extension

A Lean-To connected at the sidewall of a main building and having a roof with the same slope and level of the main building. See [Lean-To](#).

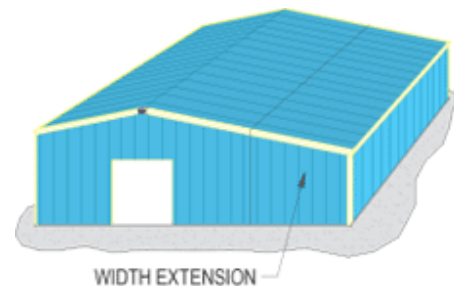



## Wind Bent

See **Portal Frame**

## Wind Column

A vertical member supporting a wall system designed to withstand horizontal wind loads usually at endwalls.

## Wind Load

A loading representing the pressure exerted on a structure by a given wind velocity. A load caused by the wind blowing from any horizontal direction.

## Z Liner

A liner which features a concealed fastener attachment with a flat surface profile. It is available in two types; Profile "D" (Sculptured) and Profile "E" (Flat).

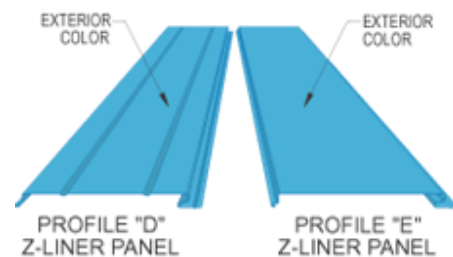

## Z Section

A member formed from coiled steel stock into the shape of a block "Z". Usually used for purlins and girts.

